



# SCOMES

Product model: FRS340/AC690V

Document number: 0ZT.198.064

Version : A - May 2023

Product name: Fuses for semiconductor protection

Manufacturer:

Scomes Srl

Address:

Via Enrico Mattei 6/8

26823 Castiglione d'Adda (LO) – Italy

[www.scomes.com](http://www.scomes.com)

## Index

1、 Scope of application and use .....	3
2、 Product model .....	4
3、 Appearance and installation dimension of fuse .....	4
4、 The tightening torque of the connecting bolts .....	4
5、 Main technical parameters .....	5
6、 Forearc time - expected current curve .....	6
7、 Service conditions .....	7
8、 Safe use and maintenance .....	13

## **1、 Scope of application and use**

### **1.1、 Scope of application and use**

This series of fuses for semiconductor equipment protection (hereinafter referred to as "fuses") are suitable for short circuit and backup protection during complete sets of power distribution, rail transit, energy storage, wind power, charging piles, electric drive systems, power conversion systems, frequency converters, etc. It has the characteristics of temperature shock, mechanical vibration/shock, current shock, chemical load, and high reliability AC breaking ability.

### **1.2、 Structural characteristics**

This series of fuses have the characteristics of small size, low fusing  $I^2t$  value, high breaking capacity and resistance to current impact.

Fuses are consumable parts, which are composed of end terminals, melt pipes, melts, fillers, etc. The melt is encapsulated in the molten tube, and the melt pipe is filled with high-purity quartz sand as the arc extinguishing medium, and the two ends of the melt are firmly electrically connected with the end to form a closed tubular busbar structure.

### **1.3、 Performance and compliance with standards**

- Rated voltage: AC690V
- Rated current: 500A、 550A、 630A、 700A、 800A、 900A、 1000A、 1100A、 1250A、 1400A、 1500A、 1600A
- Use categories: aR
- Breaking ability: AC100kA
- AC rated frequency: 45~62Hz
- The structure and performance conform to GB/T 13539.4, IEC60269, UL248; Comply with GB/T 31465 vehicle safety and environmental reliability
- Size code: 3
- RoHS compliant

## 2、 Product model

FRS 340 / □

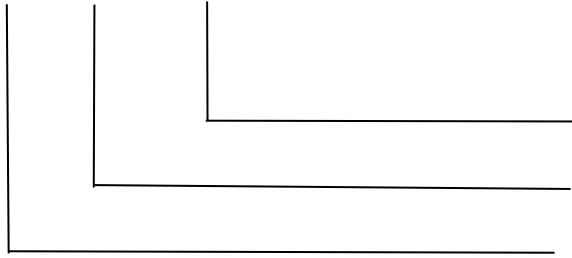

Rated current

Size code

Business code

**Model example:** FRS340/500A

Indication: Fuse FRS340 for semiconductor protection, rated current 500A

## 3、 Shape and installation size

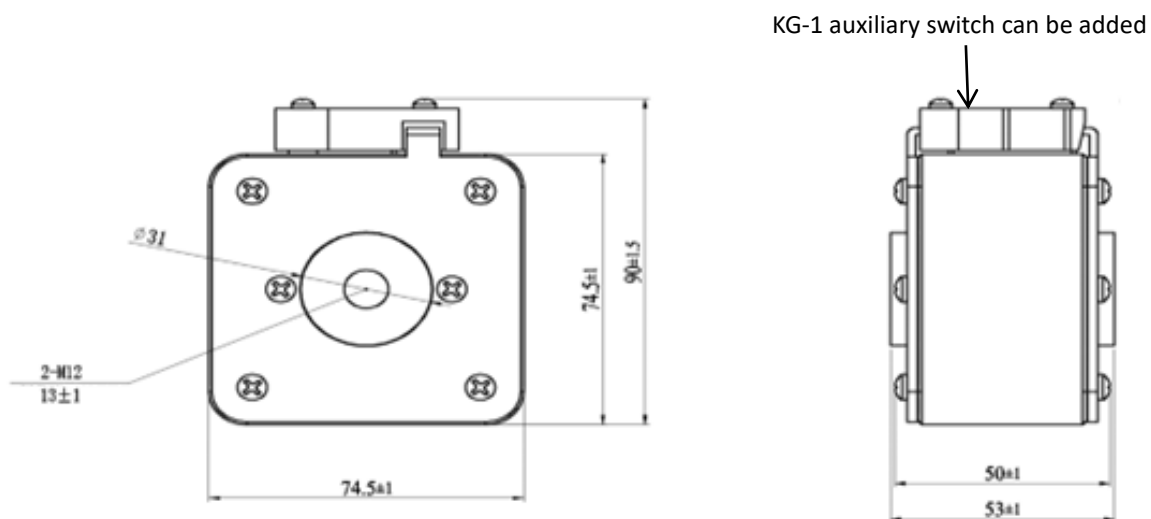

## 4、 The tightening torque of the connecting bolt

Table 1 Tightening torque of connecting bolts

screw thread	N.m (Recommended torque N.m)
M12	38±2

## 5、 Main technical parameters

Table 2, main technical parameters

products Model	size code	Rated current (A)	power loss (W)	Voltage drop (mV)	I <sup>2</sup> t (A <sup>2</sup> s)/AC690V		Installation	
					Before arc	Fusing	method	Tightening torque (N.m)
FRS	340	500	87	174	17200	96000	M12 bolt	38±2
		550	95	173	21000	124000		
		630	105	167	31000	182000		
		700	110	157	48000	286000		
		800	113	141	81000	460000		
		900	116	129	110000	630000		
		1000	127	127	134000	820000		
		1100	130	118	200000	1150000		
		1250	145	116	276000	1700000		
		1400	157	112	362000	2100000		
		1500	166	111	470000	2870000		
		1600	185	116	565000	3520000		

## 6、 Time before arc - expected current curve

Figure 1: Time before arc - expected current curve

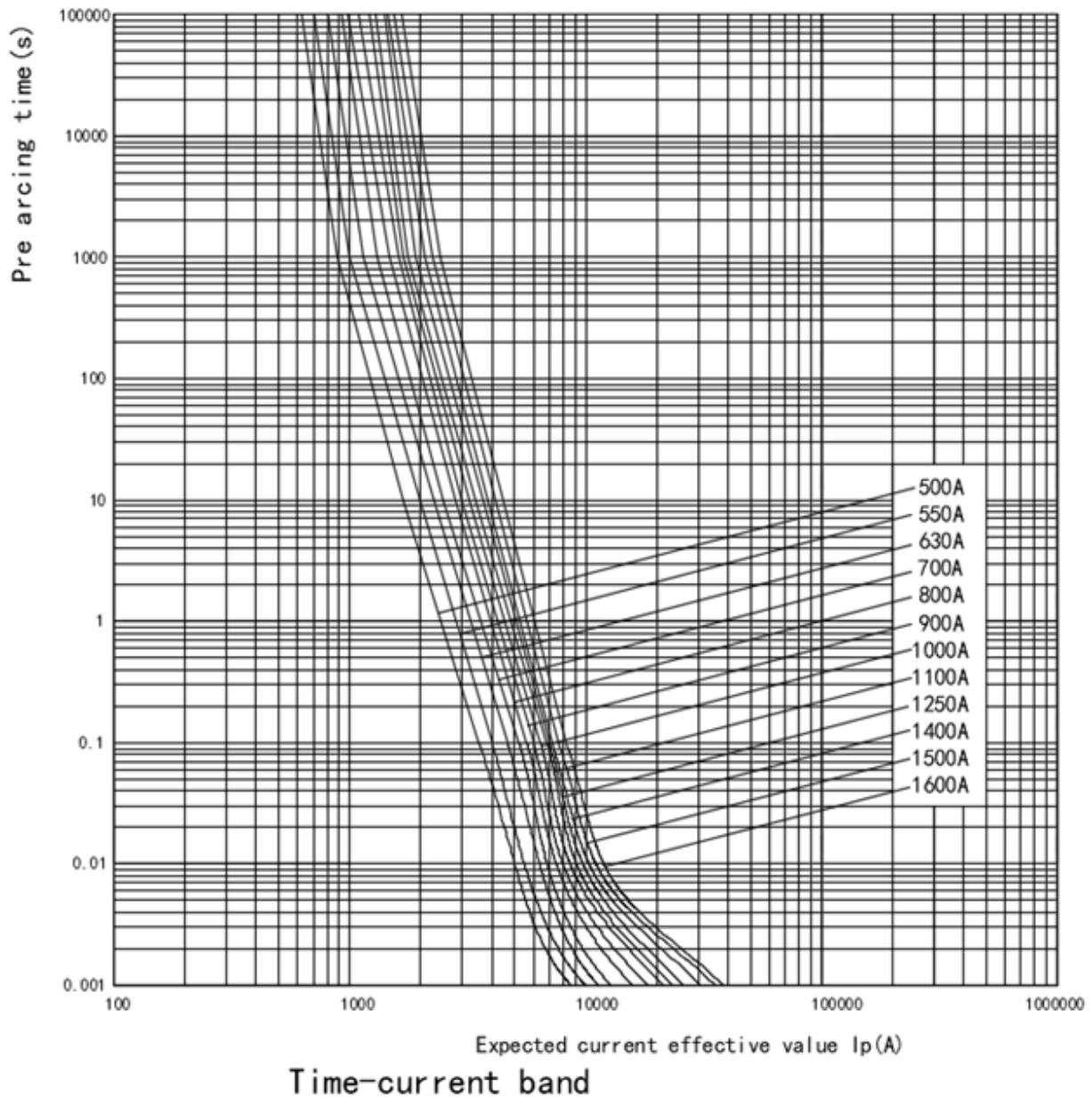

concentrate:

- 1) The characteristic curve accuracy is the current direction error :  $\pm 15\%$ ;
- 2) Minimum breaking current :  $\geq 5I_n$ ;
- 3) The above curve time is less than 100ms is the equivalent time

## 7、 Conditions of Use

### 7.1、 Normal working conditions and parameter correction

7.1.1、 The fuse operates under the normal operating conditions described below and does not require additional modifications;

7.1.2、 When exceeding the normal working conditions, if it is within the allowable working conditions, it is necessary to correct some parameters or consult our company; If the allowable work range is exceeded, we should consult our company and conduct the required work suitability assessment and test.

7.1.3、 Recommended long-term current value:  $\leq 80\%I_n$  ( $I_n$ --fuse rated current).

7.1.4、 Under a specific condition, the long-term continuous operating current  $I$  of the fuse can be calculated as follows:

$$I=I_n \times K$$

$$K=K_t \times K_s \times K_m \times K_n \times K_v \times K_w$$

Note:  $K_t$  is shown in Figure 1;  $K_s$  see Table 3;  $K_m$ ,  $K_n$ ,  $K_v$ , and  $K_w$  are shown in Figure 2, Table 6, Figure 3, and 7.4.7.2, respectively

### 7.2、 Ambient air temperature

7.2.1、 Normal working conditions:  $-5^{\circ}\text{C} \sim +40^{\circ}\text{C}$ , and the average temperature within 24h does not exceed  $+35^{\circ}\text{C}$ ;

7.2.2、 Permissible working conditions:  $-40^{\circ}\text{C} \sim +120^{\circ}\text{C}$ .

7.2.3、 Correction factor  $K_t$  for ambient air temperature change:

At an ambient temperature of  $20^{\circ}\text{C}$ , it is recommended that the actual operating current of the fuse should not exceed the rated operating current.

7.2.3.1、 When selecting the rated current of the fuse, the environment and working conditions should be considered, such as: degree of closure, air flow, size of the connecting cable (length, cross-sectional area, etc.), instantaneous current peak, etc.; The current carrying capacity test of the fuse is carried out at  $+20^{\circ}\text{C}$ , and in actual use, it is affected by the change of ambient temperature, the higher the ambient temperature, the higher the working temperature of the fuse, and the shorter its life; Working at lower temperatures will extend the life of the fuse.

The modified curve of ambient temperature and fuse carrying current is shown in Figure 1.

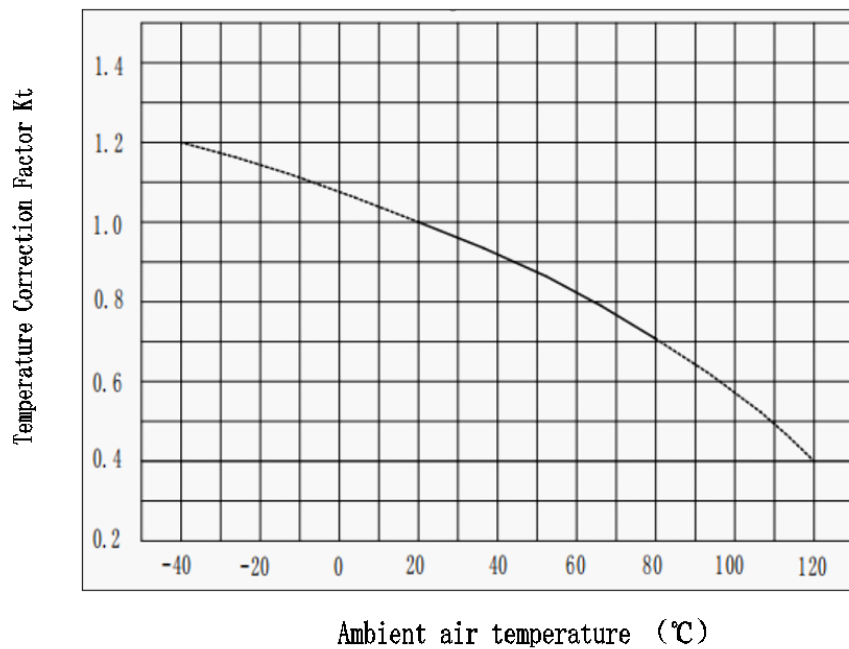

Figure 1: Correction curve and correction coefficient of ambient temperature-fuse carrying current

7.2.3.2、 for example: the ambient temperature of a certain use occasion is 20°C, the rated current of the ZTR340/500A fuse is selected  $I_n=500A$ , and the above fuse is applied in a high temperature environment of +70 °C, the working current must be additionally reduced, from the correction curve of the ambient temperature of Figure 2 - the carrying current of the fuse, it is shown that when +70 °C, the correction coefficient  $K_t=0.73$ , in order to ensure that the fuse does not malfunction The rated current value of the fuse should be reselected:  $I_e=500A/ 0.73 = 685A$ , selected according to the standard current level of the fuse:  $I_n=700A$ .

### 7.3、 elevation:

7.3.1、 Normal working conditions: altitude not exceeding 2 000m;

7.3.2、 Permissible working conditions:  $\leq 5\ 000m$ ;

7.3.3、 Parameter correction of altitude (2 000m-5 000m): higher altitude mainly brings insulation deterioration, heat dissipation conditions, and atmospheric pressure changes.

7.3.3.1、 The temperature rise of the fuse, the average ambient temperature, and the volume reduction coefficient of rated current  $I_n$  are shown in Table 3.



Table 3: Fuse temperature rise, average ambient temperature, and capacity reduction coefficient Ks of rated current In

project	The temperature rise of the fuse (K)	Average ambient temperature (°C)	The capacity reduction factor of the rated current In (Ks)
Every increase in altitude 100m	+0.5	-0.5	-
Every increase in altitude 1000m	-	-	0.95-0.98

7.3.3.2、 The multiplication coefficient of normal air pressure and electrical clearance of the fuse is shown in Table 4.

Table 4: Multiplication coefficient of normal air pressure and electrical clearance of fuse

elevation	Normal air pressure (kPa)	Multiplication factor for clearance
2 000	80.0	1.00
3 000	70.0	1.14
4 000	62.0	1.29
5 000	54.0	1.48

Note: The gap between the fuse and other live structures, as well as the insulation to the ground, needs to be considered by the user to the influence of altitude.

#### 7.4、 Installation conditions:

7.4.1、 The fuse is installed separately in natural air without ventilation, and there are no other heating parts or heat dissipation parts within 1m except for connecting wires.

7.4.2、 The fuse connection terminal should ensure stable and reliable electrical contact. The contact resistance should not significantly affect the fuse operation.

7.4.3、 The fuse can be installed vertically, horizontally or obliquely. If the fuse is guaranteed by spring pressure, a suitable position should be selected during installation to avoid the adverse effects of gravity and vibration on the electrical connection.

7.4.4、 The connecting wire section of the fuse has a significant impact, and the correction coefficient of Km--connecting wire section area is Km:

The cross-section of the copper conductor under the normal operating conditions agreed by IEC60269 is shown in Table 5 below (the current is the standard value of the long-term continuous rms value):

Table 5: Cross-sectional area of standard connected copper conductors

Rated current (A)	Connect the wires (mm <sup>2</sup> )
500	2×150 or 2× 30×5 <sup>a</sup>
550、 630	2×185 or 2× 40×5 <sup>a</sup>
700、 800	2×240 or 2× 50×5 <sup>a</sup>
900、 1000	2× 60×5 <sup>a</sup>
1100、 1250	2× 80×5 <sup>a</sup>
1400、 1500、 1600	2× 100×5 <sup>a</sup>

a indicates the recommended wire cross-sectional area for fuses connected to copper bars. For copper bars coated with black matte paint, the distance between two parallel copper bars of the same polarity should be approximately 5mm.

Km See Figure 2, the ratio of applied conductor cross-sectional area / standard cross-sectional area is 80%-120%, the effect can be ignored:

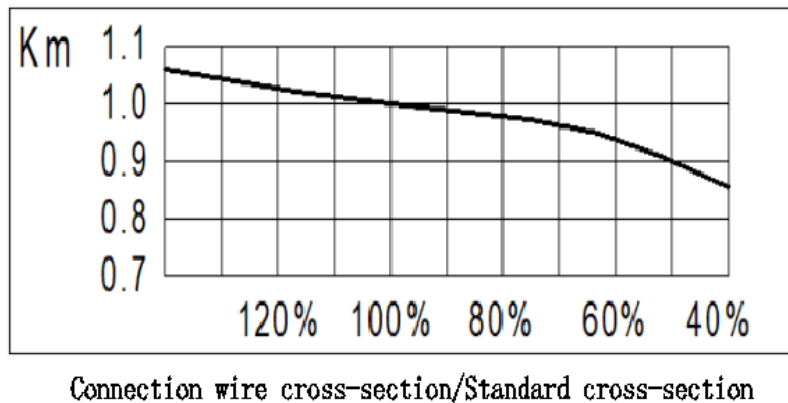

Figure 2, Km---Correction coefficient of connection section area

#### 7.4.5、 Installation in open or closed box (shell):

Due to the many types of boxes (shells), the degree of influence on the fuse is not consistent, and it is not easy to use the general correction coefficient. It is recommended that under the application conditions, test the operating temperature rise or temperature of the fuse to determine the long-term working reliability, and make a judgment according to the following operating temperature. This test can be used to verify that the correction factor for the rated current is appropriate.

In various use environments, including open or closed boxes, the fuse can withstand the following conditions:

- Class "g", long-term continuous operation, terminal temperature can allow 110 (100) °C or even higher. Short-time operation, 130°C allowed.
- It is important to note that the above conditions may not be suitable for a particular fuse and should be consulted with the manufacturer or referred to the product description.
- In any state, the long-term continuous operation of the fuse requires a state in which the structure is intact, and the deterioration of performance or aging has no cumulative effect.

#### 7.4.6、 Multiple fuses (including other heating parts) installed in the same box, Kn - the number of arrangement correction factors

Affected by many factors such as box differences, installation differences, separation distance differences, and air flow differences, it is not suitable to give a general correction coefficient. If the heat effect between multiple heat-generating components is mainly conducted through air, it can be naturalized as the influence of the ambient air temperature without additional correction.

If multiple fuses working independently are closely arranged,  $K_n$  refer to Table 6.

Table 6,  $K_n$  - Correction factor of arrangement quantity:

Layout	The juxtaposition is dense, and the cooling of the air flow between them is significantly limited			remark
Number of layouts	4-9 (pcs)	10-18 (pcs)	19-36 (pcs)	There is no significant separation in the same row in the same box, the box is not sealed
$K_n$	0.98~0.96	0.94~0.96	0.92~0.94	

#### 7.4.7、 Increase cooling

7.4.7.1、 Commonly used measures to enhance cooling: forced air cooling, single-sided water cooling, double-sided water cooling, etc. will significantly increase the rated current of the fuse.

Refer to the correction factor of the specific product specification.

#### 7.4.7.2、 Forced air cooling:

The use of forced air cooling can increase the heat dissipation of the fuse, can increase the rated current of the fuse, and the cooling effect is affected by the wind speed, air flow angle, heat dissipation area, heat dissipation power, fuse structural parameters, etc. The correction factor for wind speed and rated current— $K_v$ —is shown in Figure 3.

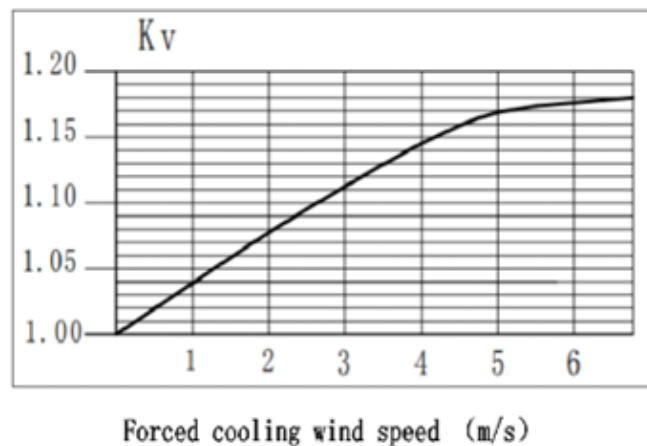

Figure 3: Correction factor for wind speed and rated current— $K_v$

#### 7.4.7.3、 Single-sided/double-sided water (liquid) cooling:

The effect of single-sided/double-sided water (liquid) cooling is affected by the area of the water-cooled busbar, the water temperature of the inlet and outlet, the heat dissipation power, and the structural parameters of the fuse, and the correction coefficient takes different values,  $K_w=1.01\sim 1.12$ .

### 7.5、 Atmospheric conditions

#### 7.5.1、 Normal working conditions

- the air is clean, and its relative humidity does not exceed 50% at a maximum temperature of 40°C.
- At lower temperatures, there can be higher relative humidity, for example, at 20°C, the relative humidity can reach 90%.
  - Under these conditions, moderate condensation may occur occasionally due to temperature changes.

#### 7.5.2、 Permissible working conditions:

In the absence of significant condensation, the relative humidity can reach 95%.

### 7.6、 The ability to shake the environment and withstand disasters such as earthquakes

7.6.1、 This series of fuses have good resistance to vibration and shock, and can withstand acceleration of more than 10G.

7.6.2、 For other application environments with strong vibration, please consult our technical department, which is generally tested and verified.

## **8、 Safe use and maintenance**

8.1、 When the fuse is installed, the minimum gap between the live parts of the adjacent two fuses meets the insulation requirements, and if necessary, install an insulating partition between the fuses to prevent phase to phase short circuit when replacing the fuse with electricity.

8.2、 Combined with regular maintenance of electrical equipment, inspection and maintenance are carried out to remove dust, oxide layer in contact with conductive parts, etc.

8.3、 Fuses with mechanical damage must be replaced.

8.4、 Unless the use requirements allow, such as: fuse load switch, do not replace the fuse with load.